

# Euclid™ Full Voltage Magnet Controller

Instructions/Parts Manual • Publication No. 180 • December 2010, Replaces May 2010

**4291 &  
4295 / 4296**

## Type 4291

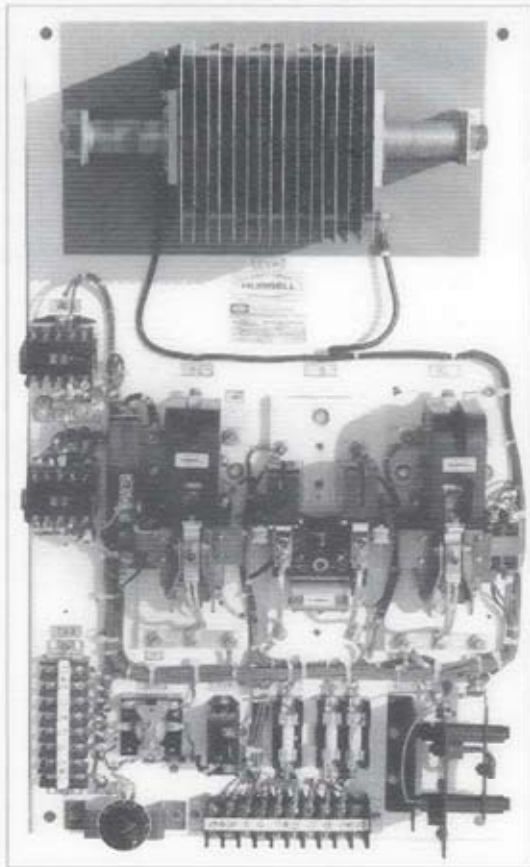

- ◆ **Varistor Discharge**
- ◆ **50 amp to 350 amp**

## Type 4295 & 4296

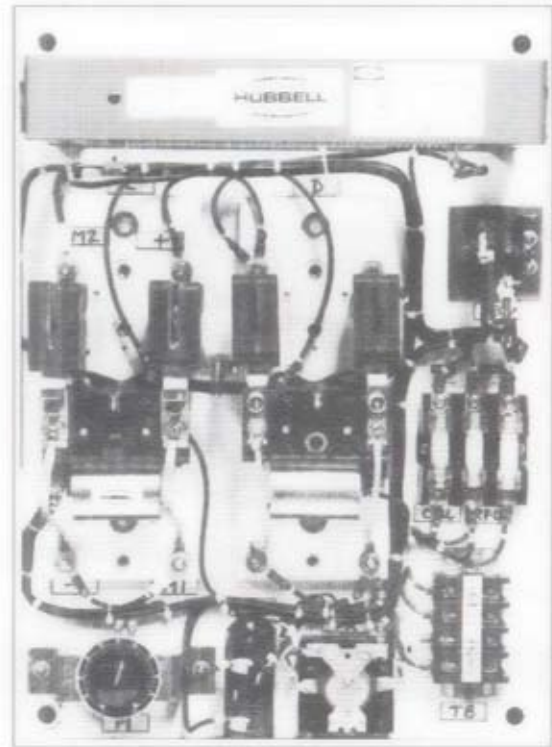

- ◆ **Resistor Discharge**
- ◆ **15 amp to 175 amp**

---

<b>Contents:</b>	4291 Description of Operation . . .	2	Lift Contactor – Size 3, 4 & 5 . . . .	12
	4295/96 Description of Operation .	3	Drop Contactors . . . . .	13
	Sequence of Operation . . . . .	4	Power Auxiliary Assembly . . . . .	13
	Installation/Troubleshooting . . . .	6	Discharge Sensor Module . . . . .	14
	4291 Part Numbers . . . . .	8	Spare Part Kits . . . . .	15
	4295/96 Part Numbers . . . . .	10	Addendum . . . . .	15

# 4291 Description of Operation

Lifting magnets operate more efficiently with greater life and safety to equipment when controlled by Hubbell Type 4291 Magnet Controllers. Magnets are cleanly discharged, permitting prompt return for another lift because of exclusive patented features.

A mechanically rugged high thermal capacity varistor assembly permanently connected around the magnet always provides a positive, safe discharge path for the stored magnetic energy. The use of a non-linear silicon carbide material in this varistor permits the fastest possible discharge of the magnetic energy and at peak voltages not exceeding 700 volts.

Inductive voltage from the magnet discharge cannot be returned to the line, permitting rectifier power supplies to be safely used without requiring special

protective load resistors or other by-pass circuitry.

Figure 1 covers the complete schematic of the basic controller. The Lift and Drop contactors designated "1L", "2L" and "D" respectively, provide a reversing circuit to the magnet. The discharge circuit is composed of the permanently connected Discharge Varistor-"DVA" and the Blocking Rectifier-"RECT".

Throwing the master switch handle to the Lift Position closes the master switch contact in the lift contactor coil circuit, thereby energizing the Lift contactors. The control circuit power is supplied through "CFU" and Rectifier-"D1". This rectifier assures that correct polarity connections have been made to the controller. No operation is possible without proper polarity being supplied.

Figure 1 –  
Type 4291 Lifting  
Magnet Control  
Automatic Discharge  
Constant Voltage  
(230V DC)  
Schematic Diagram

Sym.	Function
DR	Drop Relay
P1	Potentiometer Assembly
CFU	Control Fuse
RFU	Drop Fuses
D1	Diode
RECT	Rectifier, Magnet Discharge Path
MOV	Surge Suppressor
DVA	Discharge Varistor
DSM	Discharge Sensor Module
D	Drop Contactor
2L	Lift Contactor
1L	Lift Contactor

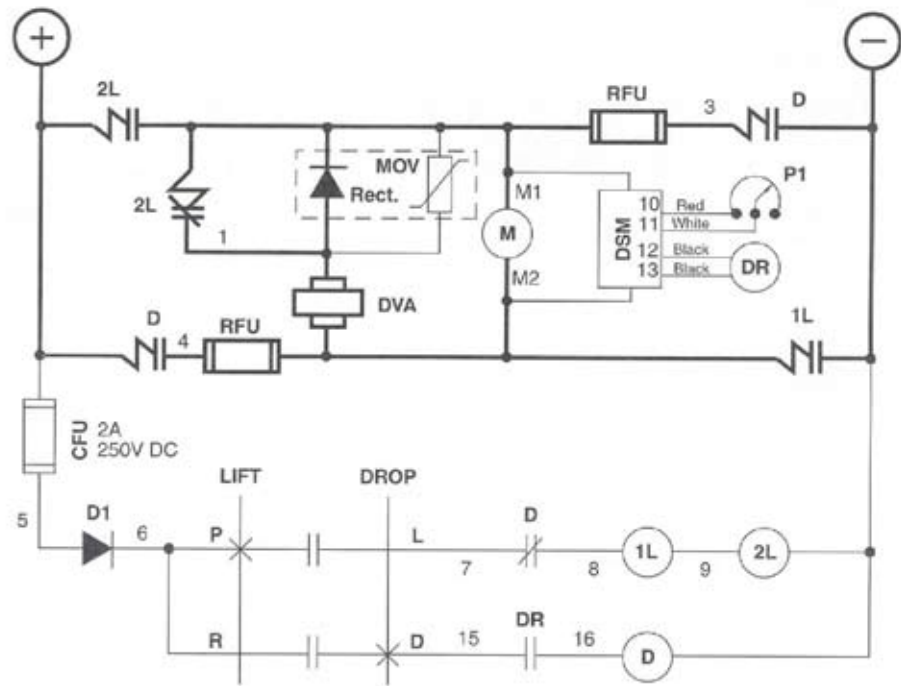

Lifting magnets operate more efficiently with greater life and safety to equipment when controlled by the Hubbell Type 4295 Magnet Controllers. Magnets are cleanly discharged, permitting prompt return for another lift because of exclusive patented features.

A mechanically rugged high thermal capacity resistor assembly permanently connected around the magnet always provides a positive, safe discharge path for the stored magnetic energy.

Inductive voltages from the magnet discharge cannot be returned to the line, permitting rectifier power supplier to be safely used without requiring special protective load resistors or other by-pass circuitry.

Figure 2 covers the complete schematic of the basic controller. The Lift and Drop contactors designated "L" and "D" respectively, provide a reversing circuit to the magnet. The discharge circuit is composed of the permanently connected resistor--"RES1" and the blocking rectifier--"D1".

Throwing the master switch handle to the Lift Position closes the master switch contact in the lift contactor coil circuit, thereby energizing the Lift contactors. The control circuit power is supplied through "CFU" and Rectifier-"D2". The rectifier assures that correct polarity connections have been made to the controller. No operation is possible without proper polarity being supplied.

A small resistor--"RES2" is connected in series with a normally closed auxiliary contact "1L" on the Lift contactor. This series combination is connected in parallel with the discharge path blocking rectifier--"D1". The purpose of this resistor is twofold:

1. This resistance forces the primary magnet discharge current to flow through the blocking rectifier--"D1" and not through the auxiliary "1L" contact, and
2. This resistance dissipates some of the remaining secondary discharge energy from the reverse current drop cycle.

## 4295/96 Description of Operation

Figure 2 –  
Type 4295 Lifting  
Magnet Control  
Automatic Discharge  
Constant Voltage  
(230V DC)  
Schematic Diagram

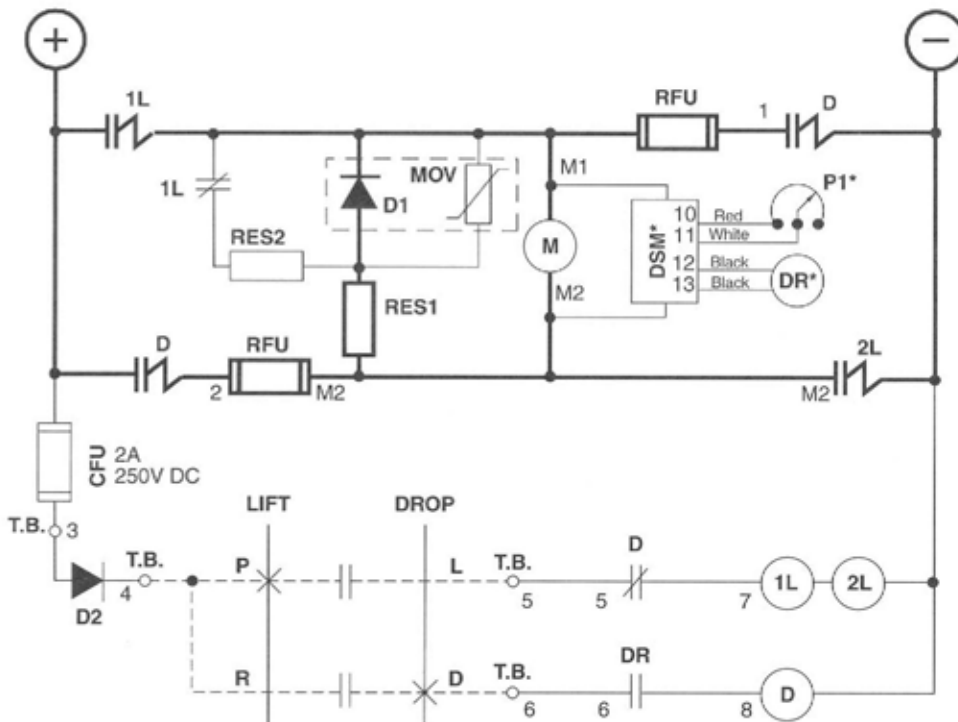

Sym.	Function
DR*	Drop Relay
P1*	Potentiometer Assembly
CFU	Control Fuse
RFU	Drop Fuses
D1	Rectifier Magnet Discharge Path
D2	Diode
MOV	Surge Suppressor
RES1	Discharge Resistor
RES2	Forcing Resistor (if used)
DSM*	Discharge Sensor Module
D	Drop Contactor
2L	Lift Contactor
1L	Lift Contactor

\* Not Used on 4296



**Figure 5 — Schematic Diagram Reverse Current Cycle, 230V DC**

1. The reverse magnet voltage resulting from the discharge cycle, Fig. 4, signals the "DSM" that the discharge cycle has begun.
2. When the reverse magnet voltage falls to 250-300 volts, the "DSM" energizes the Drop Relay "DR".
3. The Drop Relay energizes the Drop Contactor if the master switch drop contact is closed.
4. When the main Drop Contact "D" closes, the reverse magnet current begins to flow. (this is done to force the residual magnetism to zero).
5. As the "DSM" energizes the Drop Relay, it also begins the fixed time reverse current period. The drop time adjustment potentiometer "P1" determines the length of this period.
6. At the end of this fixed time period, the "DSM" deenergizes the Drop Relay which causes the Drop Contactor to open. This terminates the reverse current cleaning cycle.

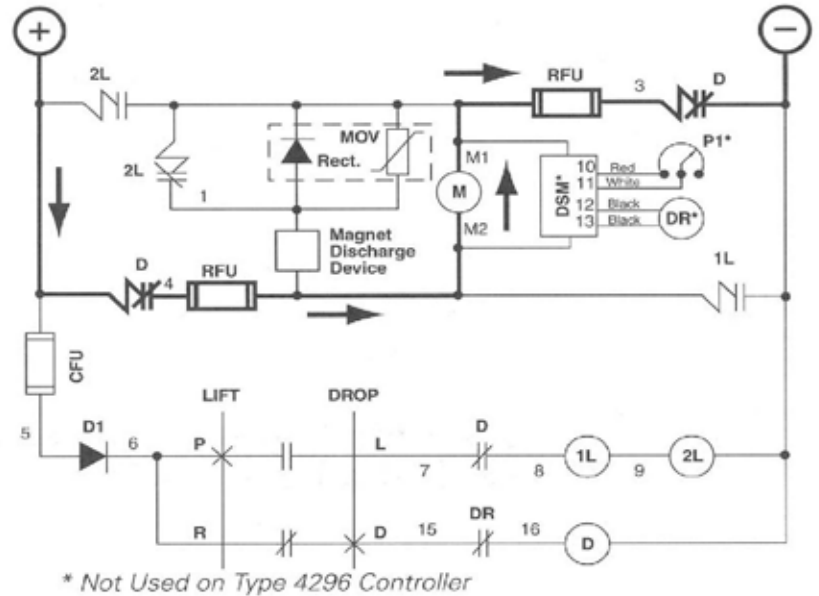

**Figure 4 — Schematic Diagram Priamy Discharge Cycle, 230V DC**

1. When the Drop Contactor "D" opens and interrupts the reverse magnet current, the magnet voltage reverses once again.
2. The remaining reverse magnet current flows through the secondary discharge path: the normally closed Lift Power Auxiliary Contact "2L" and the Discharge Varistor "DVA".

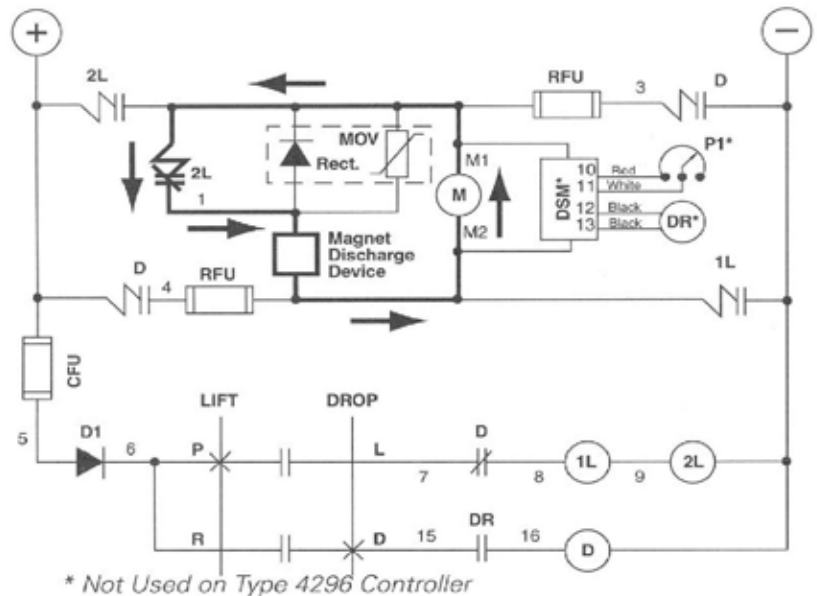

# Installation and Maintenance

Hubbell, Type 4291, 4295 and 4296 Magnet Controllers should be installed in accordance with accepted practices for installation of industrial control equipment.

Polarity of the incoming line connections MUST BE observed; these controllers will not function.

An understanding of the principle of operation will help in analyzing and in keeping this controller operating at maximum efficiency.

Basically, this controller serves the three functions necessary for magnet operation:

1. Energize the magnet for movement of load
2. Dissipate the stored energy of the magnet to release the load
3. Apply reverse current through the magnet to remove the residual magnetism effect

Two electrically and mechanically interlocked sets of contactors "LIFT" and "DROP" serve to apply the DC power for energization and reverse current cleaning respectively in two separate actions without time overlap.

The permanently connected magnet discharge path around the magnet absorbs and dissipates the stored magnet energy when the Lift contactor interrupts the supply power.

During the time of the stored energy dissipation, the reverse voltage appearing across the magnet and the discharge varistor assembly signals the discharge sensor module "DSM" that a discharge voltage falls to 250 to 300 volts, the "DSM" module closes a pilot drop relay which energizes the "DROP" contactor.

The fixed time reverse current cycle begins with the closing of the "DROP RELAY" after practically all of the stored magnet energy is dissipated by the magnet discharge device assembly. The "DSM" module also controls the length of the reverse current cycle. After a preset period, controlled by the Drop Time adjustment potentiometer, the "DSM" deenergizes the drop relay. This action causes the drop contactor to open and end the reverse current cycle.

Another unique feature of Hubbell Magnet Controllers is that full supply voltage is utilized to force the buildup of reverse current cycle thus contributing to the overall controller speed.

## Note:

Reverse current adjustment should always be made with the lightest material handled and starting with the least current. Turn the adjustment knob clockwise until the magnet drops the material cleanly. The adjusting potentiometer is mounted beside the "DSM".

Since the discharge of the magnet is a separate function from the reverse current magnet cleaning action, it is easy to obtain close control of partial load drops or to "DRIBBLE" a load if desired. A portion of the load can be dropped merely by moving the master switch handle midway between the lift and drop positions to open the "LIFT" contactor without "SETTING UP" the automatic drop cycle.

## Contactor Maintenance

For proper maintenance of the "LIFT" and "DROP" contactors refer to the following Hubbell Contactor Service Publications:

Contactor Size	Contactor Series	RPC Number
2	59322	59323-1
3	59335	59335-1, -2
4	59345	59345-1, -2
5	59495	59495-003, 4
5A	59676	59656-003, 4

# Trouble-shooting

*The following covers a general list of possible troubles that may be encountered with the causes and suggested cures given respectively. See pages 8-13 for renewal parts information.*

## RES1 Value

Magnet Current (amps)	RES1 Values (ohms)
13-25	80
25-50	23
50-80	11.3
85-130	6.9
130-175	4.7

Consult factory if further recommendations or troubleshooting assistance are desired. Call 336/434-2800

Symptom	Possible Cause	Diagnosis/Action
<b>“Lift” contactor does not pick up.</b>	Polarity not observed at time of controller installation. Lift contactor coil circuit open. CFU or Diode D1 open.	Reverse the supply power connections to the controller. Check continuity of lift contactor coils. Check master switch contacts. Replace CFU or D1.
<b>Magnet does not clean properly.</b>	Reverse current cycle time is too short. Drop contactor does not remain closed long enough to clean magnet. Reverse current cycle time is too long. Drop contactor remains closed too long & allows excessive reverse current build-up. Drop contactor operate but no reverse current flows 4291 DVA varistor path circuit open. 4295 and 4296 RES1 resistor path circuit open.	Increase the Drop Time adjustment potentiometer setting (clockwise rotation). Decrease the Drop Time adjustment potentiometer setting (counter clockwise rotation). Replace RFU fuses. Check DVA. IF fins are warped or ohm value is under 50k ohms, varistor may be defective. Replace. Check continuity in RES1. If open circuit replace. Correct values shown in table to right.
<b>“Drop” contactor does not operate.</b>	Drop contactor coil circuit open. Reversed M2-M1 connections to the DSM. Faulty drop relay. Faulty DSM	Check continuity of Drop contactor coils. Check master switch contacts. Check DSM wiring and correct if necessary. Replace drop relay. Replace DSM (see page 14).
<b>Drop contactor operates but does not drop out.</b>	Faulty drop time adjustment potentiometer or open potentiometer circuit. Faulty DSM	Repair or replace potentiometer assembly or wiring. Replace DSM (see page 14).
<b>No adjustment of the reverse current cycle.</b>	Faulty drop time adjustment potentiometer. Faulty DSM	Replace potentiometer assembly. Replace DSM (see page 14).
<b>Magnet discharge device over heats.</b>	Too many magnet discharges per minute. Blocking rectifier is shorted. Full line voltage applied to magnet discharge device during lift cycle.	Avoid frequent cycling or use controller with increased capacity. Replace blocking rectifier assembly.

## 4291 Part Numbers for Renewal Parts

Product Component Description	Maximum Cold Magnet Current				
	50 Amp	150 Amp	175 Amp	350 Amp	500 Amp
Magnet Controller Size	2	3	4	5	5A
<b>DVA</b> Discharge Varistor	HC03009020	HC03009040	HC03009050	HC03009053	HC03009027
<b>RECT/MOV</b> Rectifier/Surge Suppressor	HC71386005	HC71386001	HC71386001	HC71386001	HC71386021
<b>RFU</b> Drop Fuses	HC57361663 15A, 600V	HC57361757 20A, 600V	HC57361757 20A, 600V	HC57361757 45A, 600V	HC57361773 60A, 600V
<b>D1</b> Diode	HC57355001	HC57355001	HC57355001	HC57355001	HC47288066
<b>DSM</b> Discharge Sensor Module	HC48684001	HC48684001	HC48684001	HC48684001	HC48684001
<b>DR</b> Drop Relay	HC31658038	HC31658038	HC31658038	HC31658038	HC31658038
<b>P1</b> Potentiometer Assembly	HC48686001	HC48686001	HC48686001	HC48686001	HC48686001
<b>D</b> Drop Contactor *	5210-59312-107	5210-59322-104	5210-59322-104	5210-59335-011	5210-59335-011
<b>CFU</b> Control Fuse	HC57361752 3A, 250V	HC57361752 3A, 250V	HC57361752 3A, 250V	HC57361752 3A, 250V	HC57361752 3A, 250V
<b>2L</b> Lift Contactor * Incl. Power Auxiliary assembly	5210-59325-101	5210-59335-802	5210-59345-802	5210-59495-811	5210-59656-861
<b>1L</b> Lift Contactor *	5210-59321-102	5210-59335-011	5210-59345-011	5210-59495-011	5210-59656-011
<b>DCR-LCR</b> Drop-Lift Relay	HC57418326	HC57418326	HC57418326	HC57418326	HC57418326
<b>Auxiliary Contact Block</b> N.O. & N.C. for "D"	HC68011003	HC68011003	HC68011003	HC68011003	HC68011003
<b>Power Auxiliary Block</b> For "2L"	HC59509001	HC70472001	HC70472011	HC70472012	HC70472022
<b>Mechanical Interlocks</b>	HC68015002	HC71696001	HC71696001	HC58671007	HC58671007

\* See Contactor Part Selection Pages 12-13.

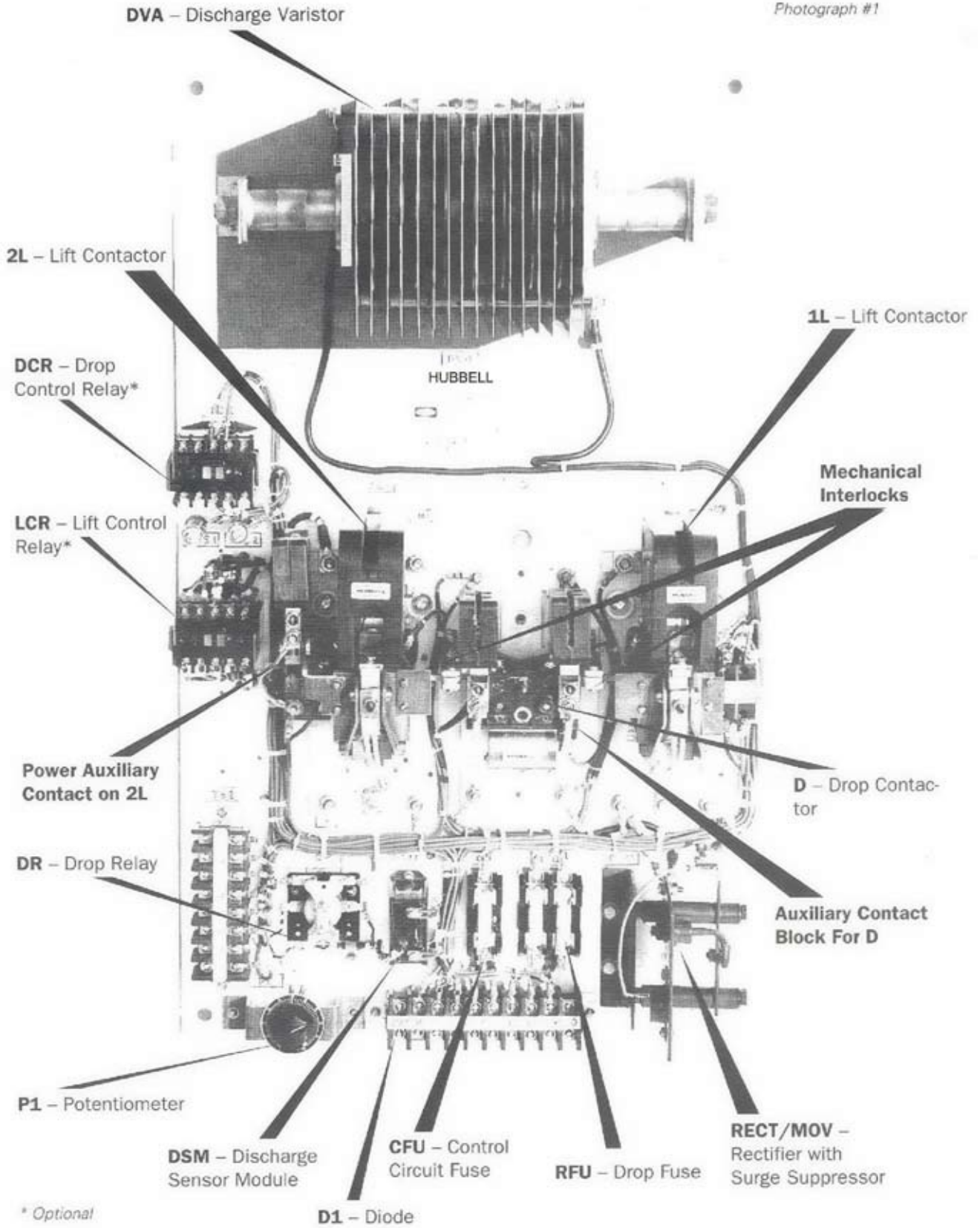

# 4295/96 Part Numbers For Renewal Parts

Product Component Description	Maximum Cold Magnet Current				
	25 Amp	50 Amp	85 Amp	130 Amp	175 Amp
<i>Magnet Controller Size</i> →	1	2	3	3	4
<b>RES 1</b> Discharge Resistor Assembly	69451-855	69451-856	69451-857	69451-858	69451-859
<b>RECT/MOV</b> Rectifier/Surge Suppressor	71386-005	71386-005	71386-006	71386-007	71386-007
<b>RFU</b> Drop Fuses	57361-755 10A, 250V	57361-756 15A, 250V	57361-757 20A, 250V	57361-758 25A, 250V	57361-758 25A, 250V
<b>D1</b> Diode	47288-066	47288-066	47288-066	47288-066	47288-066
<b>DSM* *</b> Discharge Sensor Module	48684-001	48684-001	48684-001	48684-001	48684-001
<b>DR* *</b> Drop Relay	31658-038	31658-038	31658-038	31658-038	31658-038
<b>P1* *</b> Potentiometer Assembly	48686-001	48686-001	48686-001	48686-001	48686-001
<b>D</b> Drop Contactor *	5210-59312-107	5210-59322-103	5210-59322-104	5210-59322-104	5210-59322-104
<b>CFU</b> Control Fuse	57361-752 2A, 250V	57361-752 2A, 250V	57361-752 2A, 250V	57361-752 2A, 250V	57361-752 2A, 250V
<b>2L</b> Lift Contactor *	5210-59322-103	5210-59332-104	5210-59335-802	5210-59335-802	5210-59335-802
<b>1L</b> Lift Contactor *	--	--	5210-59335-011	5210-59335-011	5210-59345-011
<b>Auxiliary contact Block</b> N.O. & N.C. For "D"	68011-003	68011-003	68011-003	68011-003	68011-003
<b>RES 2</b> Forcing Resistor	--	--	57419-035	57419-035	57419-035
<b>Mechanical Interlocks</b>	68015-002	68015-002	71696-001	71696-001	71696-001

\* See Contact Part Selection Pg. 12 & 13

\* \* These items are not used on Type 4296 Controller

### RES1 – Discharge Resistor Assembly (4295)

Assembly P/N	69451-885	69451-856	69451-857	69451-858	69451-859
Res. Coils Used	1 – Size 3	2 – Size 3	3 – Size 3	3 – Size 3	5 – Size 5
Res. Coil Ratings	2A, 40Ω	5.5A, 11.5Ω	11A, 3.75Ω	15A, 2.14Ω	24A, .945Ω
Res. Coil P/N	69423-004	69323-001	69323-005	69323-009	69323-014

### RES1 – Discharge Resistor Assembly (4296)

Assembly P/N	69451-885	69451-856	69451-857	69451-858	69451-859
Res. Coils Used	1 – Size 3	2 – Size 3	3 – Size 3	3 – Size 3	5 – Size 5
Res. Coil Ratings	2A, 40Ω	5.5A, 11.5Ω	11A, 3.75Ω	15A, 2.14Ω	24A, .945Ω
Res. Coil P/N	69423-004	69323-001	69323-005	69323-009	69323-014

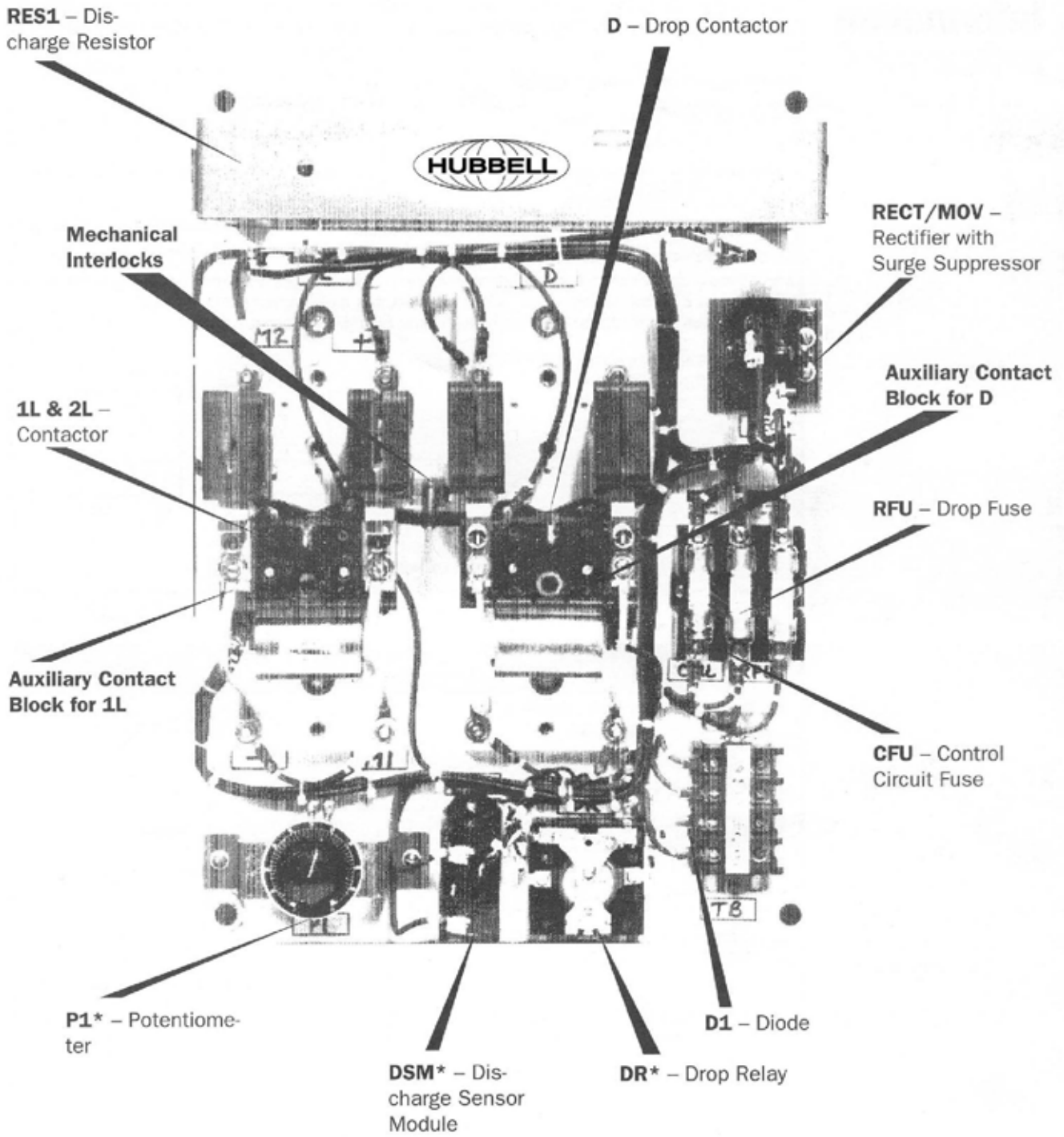

\* Not Used on 4296 Controllers

## Lift Contactor Size 3/4

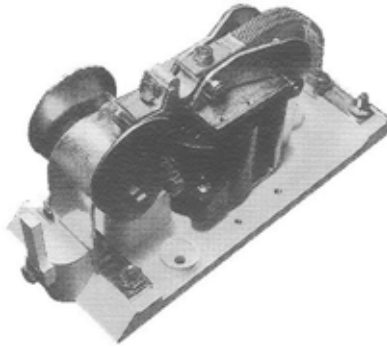

## Lift Contactor Series 59335 (Size 3) & 59345 (Size 4)

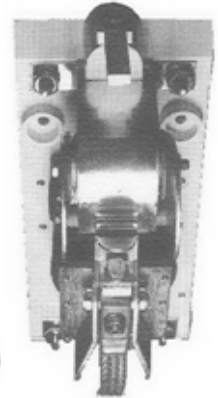
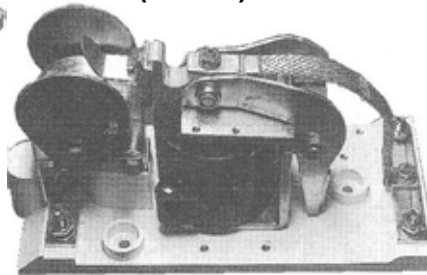

Photograph #3

### Renewal Parts

for exploded view of contactor  
see RPC 59335-1, -2 for Size 3 and  
see RPC 59345-1, -2 for Size 4

- 1) Single Pole Contact Kit (includes items 2, 3 & 4 plus hardware)
  - Size 3 ("L" Tip) ..... P/N 59672-103
  - Size 4 ("L" Tip) ..... P/N 59672-105
- 2) Contact Tips (2 req'd per contactor)
  - Size 3 ("L" Tip) ..... P/N 16924-000
  - Size 4 ("L" Tip) ..... P/N 17279-000
- 3) Arc Horn ..... P/N 68056-001
- 4) Contact Sprints (silver)..... P/N 16960-000 (silver)
- 5) Movable Contact Holder ..... P/N 16927-000
- 6) Arc Shield Assembly
  - Size 3 ..... P/N 16973-000
  - Size 4 ..... P/N 16993-000
- 7) Operating Coil (1 req'd per contactor)
  - 57.5V Coil (for 115V systems) ..... P/N 17488-000
  - 115/125V Coil (for 230V systems) ..... P/N 17487-000
- 8) Auxiliary contact Block Kit ..... P/N 68040-001
- 9) 2L Power Auxiliary Contact ..... see page 13

## Lift Contactor Size 5



## Lift Contactor Series 59495 (Size 5) 59656 (Size 5A)



### Renewal Parts

(see Publication #174 for exploded view of contactor)

1. Single Pole Contact Kit (includes items 2, 3 & 4 plus hardware)
  - Size 5/5A ..... P/N 59672-024
2. Contact Tips (2 req'd per contactor)
3. Size 5/5A ..... P/N 18402-000
4. Contact Spring ..... P/N 67981-030
5. Arc Horn ..... P/N 59465-002
6. Arc Shield Assembly ..... P/N 18063-000
7. Operating Coil (1 req'd per contactor)
8. 57.5V Coil (for 115V systems) ..... P/N 67890-005
9. 115/125V Coil (for 230V systems) ..... P/N 67890-003
10. Auxiliary contact Block Kit ..... P/N 68040-008
11. 2L Power Auxiliary Contact ..... see page 13

## Drop Contactor Size 2

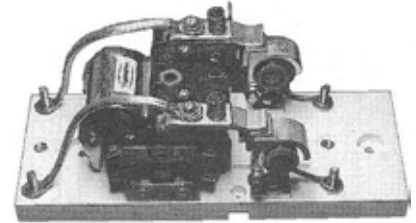
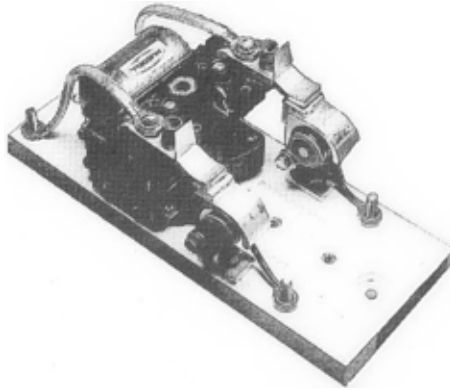

Photograph #7

### Renewal Parts

(see RPC 59323-1 for exploded view of contactor)

- |                                                                    |               |
|--------------------------------------------------------------------|---------------|
| 1) Single Pole Contact Kit (includes items 2, 3 & 4 plus hardware) | P/N 59672-003 |
| 2) Contact Tips (2 req'd per contactor)                            | P/N 2317-000  |
| 3) Contact Finger (2 req'd per contactor)                          | P/N 5722-000  |
| 4) Contact Springs                                                 | P/N 8838-000  |
| 5) Arc Horn                                                        | P/N 42029-000 |
| 6) Arc Shield Assembly                                             | P/N 42856-000 |
| 7) Operating Coil (1 req'd per contactor)                          |               |
| 115V Coil (for 115V systems)                                       | P/N 68014-002 |
| 250V Coil (for 230V systems)                                       | P/N 68014-001 |
| 8) Auxiliary contact Block Kit                                     | P/N 68040-003 |

Size 2 drop contactor used on Size 3 & 4 controllers.

## 2L Power Auxiliary Assembly (for Type 4291 Controllers only)

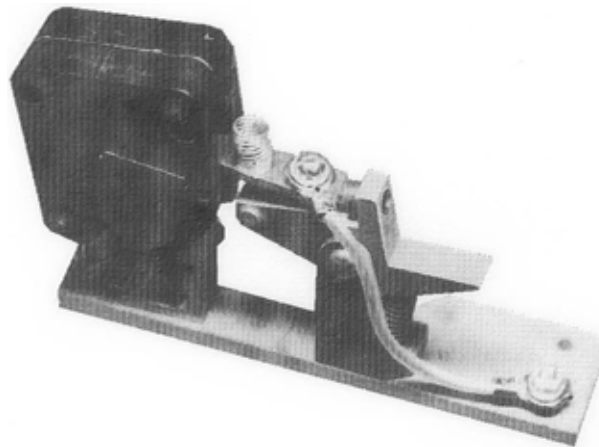

### Renewal Parts

- |                                                         |               |
|---------------------------------------------------------|---------------|
| 1) Contact Kit (includes items 2, 3, & 4 plus hardware) | P/N 59672-014 |
| 2) Movable Finger                                       | P/N 17718-003 |
| 3) Stationary Tip                                       | P/N 02315-000 |
| 4) Finger Spring                                        | P/N 17716-000 |
| 5) Arc Shield Assembly                                  | P/N 42855-000 |
| 6) Shunt                                                | P/N 09298-000 |

## Discharge Sensor Module (DSM)

The DSM, Discharge Sensor Module, is a potted electronic assembly which operates a pilot relay. This module monitors the primary discharge voltage of a lifting magnet and controls the drop contactor during the drop cycle. The DSM contains a voltage sensing section and an adjustable timing section. The voltage sensing section causes the drop contactor to engage when the discharge voltage falls to about 250V. The adjustable timing section controls the length of time that the drop contactor is engaged. This adjustment allows the magnet controller to be set to clean the magnet.

Small magnets, generally size 2 through the low end of size 3 controllers, will require the short range timing. This range is available by leaving the exposed resistor on top of the DSM assembly intact. Larger magnets, mid range size 3 through size 4, will require the extended range timing. This range is selected by "Clipping Out" the exposed resistor.

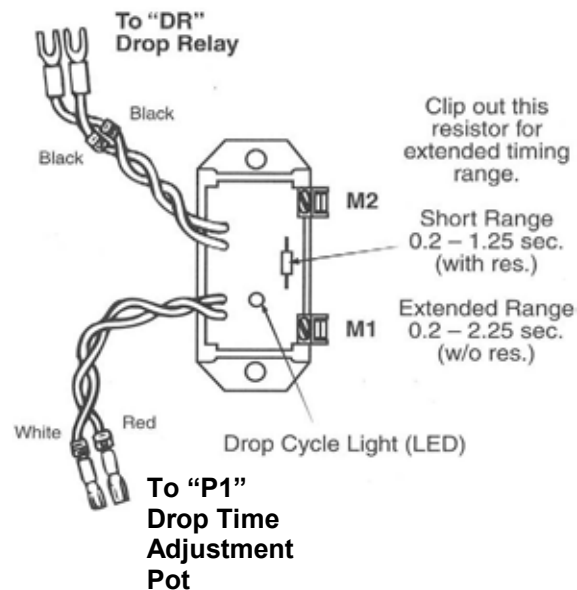
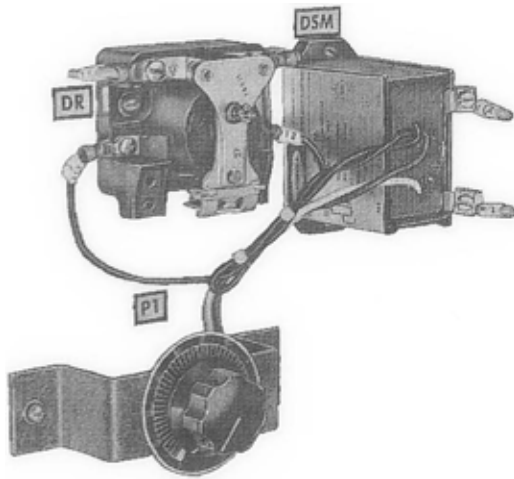

### Troubleshooting

The operation of the DSM can be verified by watching the magnet controller operation:

1. When the lift circuit opens, the magnet begins discharging through the primary discharge path. As the magnet energy is expanded, the discharge voltage falls.
2. When the discharge voltage falls to 250-300V, the DSM causes the drop relay to operate. At the same time, the drop cycle LED on the DSM lights.
3. When the drop relay closes, the drop contactor picks up and begins the controller's reverse current cycle.
4. After the pre-set drop time has expired, the DSM de-energizes the drop relay. The drop cycle LED on the DSM goes out.
5. The drop time potentiometer, P1, is used to adjust the drop time to suit the particular magnet and load.

# Magnet Controller Contact Kit

Used With Magnet Controller Size	Spare Parts Kit Part Number	Spare Parts Kit Includes
NEMA Size 1	59403-108	
NEMA Size 2	59403-101	
NEMA Size 3 with contactor series 59335	59403-102	1 – Set of movable and stationary contacts for "Lift" contactors
NEMA Size 4 with contactor series 59345	59403-103	1 – Set of movable and stationary contacts for "Drop" contactors 1 – Set of movable contact springs for "Lift" and "Drop" contactor
NEMA Size 5 with contactor series 59495	59403-207	1 – Set of Arc Horns for "Lift" and "Drop" contactors 1 – Auxiliary Contact Block  1 – Replacement hardware to mount new parts  1 – Finger, Tip & Springs for Power Auxiliary Assembly

## ADDENDUM TO PUBLICATION 180 FOR REDUCED VOLTAGE BULL 4291

The magnet economizing circuit (reduced voltage control circuit) is energized with DC line voltage at all times. When the control is at rest, the ME contactor is picked up through the normally closed contact on 1L and the RES1 resistor. This contactor has a 115-volt coil (on 230V systems), and RES1 drops the other half (115V) of the supply voltage. The 1L contact is bypassed or "latched" by the normally open auxiliary on ME. When the lift contactors are energized, the 1L contact opens and the 2L contact closes, leaving ME sealed in by its own auxiliary. This starts the 1AT across the ME coil to 0, and the contactor drops open. The full 230V control voltage is now placed across RES1, which maintains current through 1AT to keep it closed, and ME open. When the drop cycle is started, the 2L aux. opens, the 1L aux. recloses, and ME picks up instantly. An arc suppressor, AI, is standard across ME to protect the timer from voltage surges.

When ME is closed at rest, it bypasses the economizing resistor R1-R2. During the first few seconds of lift, full voltage is placed across the magnet M1-M2, to "pick" the load. When 1AT times out and ME opens, the economizing resistor is placed in series with the magnet, reducing the magnet voltage to the "transport" value so that the magnet will not overheat during long lift cycles. The economizing resistor must be properly matched to the magnet so that the voltage on the magnet is reduced enough to keep it cool, but not so low that it will drop any of the load. Typical magnet voltages are 230-275V for lifting; and 180-200V reduced.



## Hubbell Industrial Controls, Inc

a subsidiary of Hubbell Inc.

4301 Cheyenne Dr., Archdale, NC 27263

Telephone (336) 434-2800 • FAX (336) 434-2803

<http://www.hubbell-icd.com>

[Sales@hubbell-icd.com](mailto:Sales@hubbell-icd.com)