



hubbell industrial controls, inc.

INSTRUCTIONS

2210

Publication No. 134
January 1987
Repl.: August 1984

REPAIR PARTS

EUCLID 2210 TYPE C SPEED SWITCH

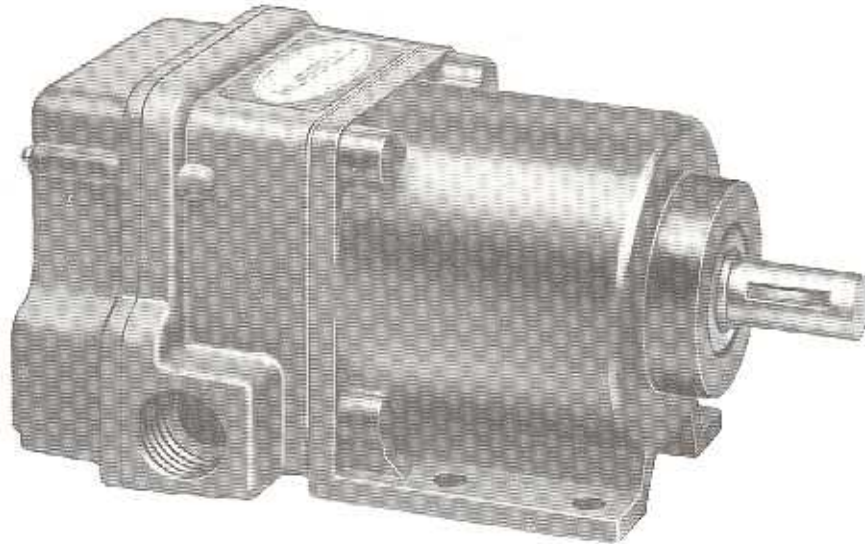

USE WITH THE FOLLOWING SPEED SWITCHES:

<u>BASIC SWITCH CAT. NUMBER</u>	<u>WITH</u>	<u>ENCLOSURES</u>	<u>AND</u>	<u>OPTIONS</u>
2210-132CC	}	13	}	NONE
-133CC				F
-222CC				M
-223CC				S
-232CC				FS
-233CC				FM
-312CC				FSM
-313CC				FSMM
-322CC				MM
2210-132DD				SM
-132DC				SMM
-222DD				SS
-222DC				SSM
-232DD				SSMM
-232DC				
-312DD				
-312DC				
		4		
		7		
		9		
		10		

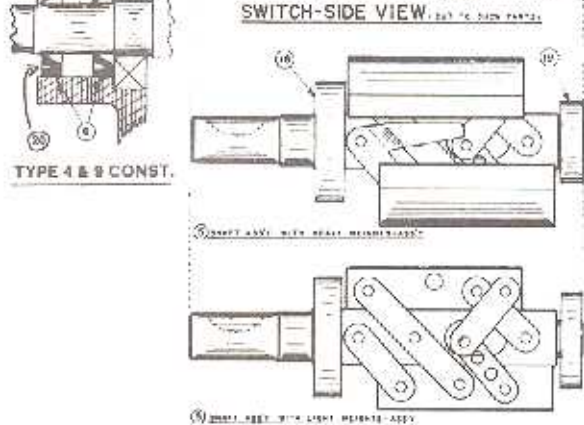
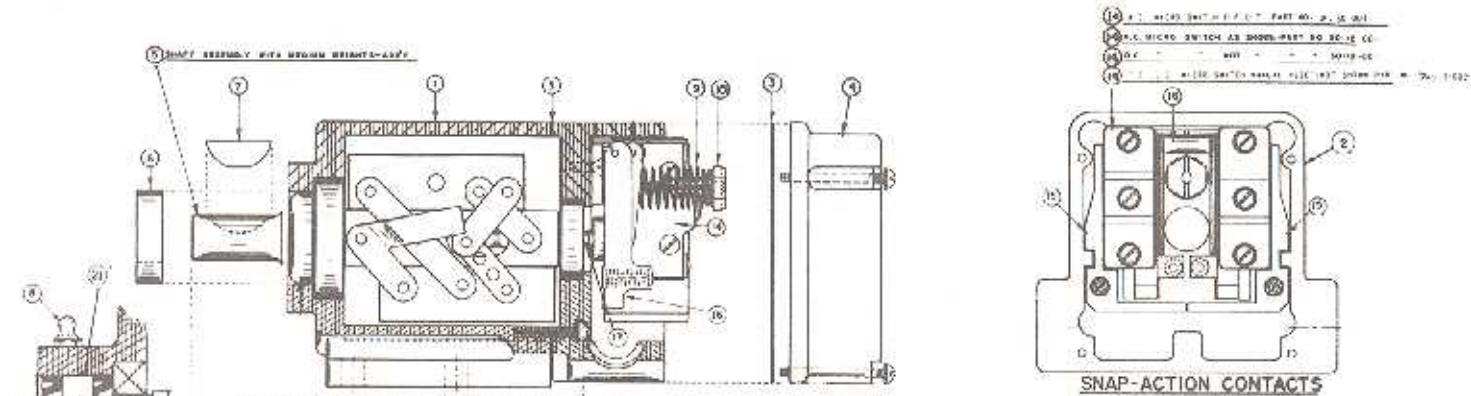

REF NO	PART NO	NO. REQ'D	PART NAME
1	25711-000	1	MAIN HOUSING NEMA 13
1	30540-000	1	MAIN HOUSING NEMA 4
1	30069-000	1	MAIN HOUSING MACH. FOR SPEED INCREASER
1	25712-000	1	MAIN HOUSING FLANGE MOUNTING "A" FACE
1	30350-000	1	MAIN HOUSING FLANGE MOUNTING INT. SPD. INC. "B" FACE
1	30359-000	1	MAIN HOUSING FLANGE MTD. INT. SPD. INC. "A" FACE
1	30090-000	1	MAIN HOUSING NEMA 7
1	30187-000	1	MAIN HOUSING NEMA 10
1	30058-000	1	MAIN HOUSING MACHINED FOR SPEED INCREASER NEMA 9 & 7
1	30584-000	1	MAIN HOUSING MACHINED FOR SPEED INCREASER NEMA 10
1	30182-000	1	FLANGE MTG. HOUSING NEMA 7, 9
1	30415-000	1	MAIN HOUSING NEMA 9
2	55049-000	1	CONTACT HOUSING ONE CONTACT
2	55050-000	1	CONTACT HOUSING TWO CONTACTS
2	55052-000	1	CONTACT HOUSING ONE CONTACT NEMA 7, 9
2	55051-000	1	CONTACT HOUSING TWO CONTACTS NEMA 7, 9
3	30556-000	1	REAR COVER GASKET
3	25819-000	1	CONTACT HOUSING GASKET
4	55062-001	1	REAR COVER ASSEMBLY - STANDARD
4	55062-006	1	REAR COVER ASSEMBLY 1 BUTTON
4	55062-007	1	REAR COVER ASSEMBLY 2 BUTTONS
4	30583-000	1	COVER NEMA 7, 9 & 10
4	55067-001	1	COVER FOR L.H. SWITCH NEMA 7, 9
4	55067-002	1	COVER FOR L.H. & R.H. SWITCH NEMA 7, 9
5	55038-001	1	SHAFT ASSEMBLY-LIGHT WEIGHTS NEMA 13
5	55038-002	1	SHAFT ASSEMBLY-LIGHT WEIGHTS SPD. INC. NEMA 4 & 13
5	55038-005	1	SHAFT ASSEMBLY-LIGHT WEIGHTS NEMA 4, 7, 9, 10
5	55040-001	1	SHAFT ASSEMBLY-MEDIUM WEIGHTS NEMA 13
5	55040-002	1	SHAFT ASSEMBLY-MEDIUM WEIGHTS SPD. INC. NEMA 4 & 13
5	55040-003	1	SHAFT ASSEMBLY-MEDIUM WEIGHTS NEMA 4, 7, 9, 10
5	55042-001	1	SHAFT ASSEMBLY-HEAVY WEIGHTS NEMA 13
5	55042-002	1	SHAFT ASSEMBLY-HEAVY WEIGHTS SPD. INC. NEMA 4 & 13
5	55042-005	1	SHAFT ASSEMBLY-HEAVY WEIGHTS NEMA 4, 7, 9, 10
5	55040-006	1	SHAFT ASSEMBLY WITH MEDIUM WEIGHTS SPD. INC. NEMA 7, 9 & 10
5	55042-006	1	SHAFT ASSEMBLY WITH HEAVY WEIGHTS SPD. INC. NEMA 7, 9 & 10
5	55038-008	1	SHAFT ASSEMBLY WITH LIGHT WEIGHTS SPD. INC. NEMA 7, 9 & 10
6	57497-007	1	SHAFT SEAL NEMA 13
6	57497-012	2	SHAFT SEAL NEMA 4
6	57497-004	2	SHAFT SEAL NEMA 7, 9
7	57458-002	1	1/11 WOODRUFF KEY
8	57353-004	1	GREASE FITTING NEMA 4
8	57353-002	1	GREASE FITTING NEMA 9
9	30012-000	1	ADJUSTMENT SPRING-LIGHT 14 TURNS .041 M.W. #3
9	30013-000	1	ADJUSTMENT SPRING-MEDIUM 11 TURNS .055 M.W. #2
9	30014-000	1	ADJUSTMENT SPRING-HEAVY 11 TURNS .067 M.W. #1
10	30067-000	1	ADJUSTMENT NUT
14	30112-001	1 OR 2	MICRO SWITCH A.C. S.P.D.T.
14	30113-001	1 OR 2	MICRO SWITCH D.C. S.P.D.T.
14	25813-002	1 OR 2	MICRO SWITCH A.C. OR D.C. S.P.D.T. MANUAL RESET
14	30105-001	1 OR 2	MICRO SWITCH A.C. D.P.D.T.
15	25958-001	1	MICRO SWITCH ADJUSTMENT BRACKET L.H.
15	25958-002	1	MICRO SWITCH ADJUSTMENT BRACKET R.H.
16	25818-000	1	OPERATING LEVER & PUSH ROD ASSEMBLY L.H. NEMA 4, 13
16	25818-100	1	OPERATING LEVER & PUSH ROD ASSEMBLY L.H. NEMA 4, 13
16	25818-102	1	OPERATING LEVER & PUSH ROD ASSEMBLY L.H. NEMA 7, 9, 10
17	25843-000	1	OPERATOR SHAFT ASSEMBLY
18	57320-016	1	BEARING, FRONT MAIN
19	57320-015	1	BEARING, REAR MAIN
20	30425-000	1	SPAL RETAINER
21	30419-000	1	SEAL SPACER NEMA 9

*RECOMMENDED PARTS FOR MAINTENANCE

NOTE: WHEN ORDERING REPLACEMENT PARTS FOR CATALOG NO. 2510-CENTRIFUGAL SWITCH KINDLY FURNISH COMPLETE CATALOG NO. & SERIAL NO., AS SHOWN ON THE IDENTIFICATION NAME PLATE. ORDER PARTS BY PART NUMBER & PART NAME.



Hubbell Industrial Controls, Inc.
 a subsidiary of HUBBELL INCORPORATED
 50 Edwards Street, Madison, Ohio 44057
 Telephone (216) 428-1161 • FAX 216-428-7635